



Technical Bulletin 00411

www.jcm-american.com

The JCM web site provides the tools you need, including the software information database with DIP switch information, our photo parts catalog, online ordering form, repair service, and more.

Parts are Parts

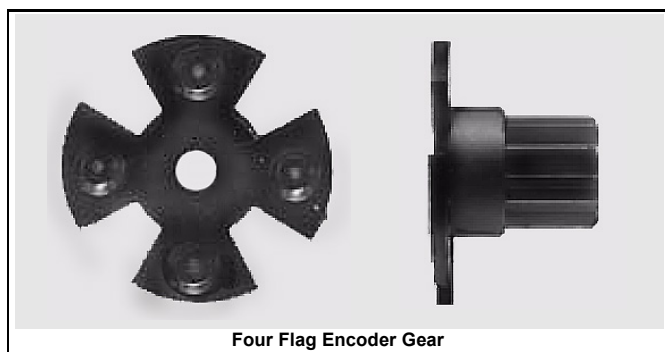

Four Flag Encoder Gear

Part No. 052534

Description: WBA Encoder Gear, Four Flag

Usage: The four flag encoder gear is a compression fit gear used to control timing on our WBA product line. It controls the advanced optical and magnetic sensor data collection timing as a note or coupon/ticket moves through the bill acceptance path.

Note: The new design includes a collar on the shaft which increased the strength and durability of this component. The earlier design of this gear can develop a hairline crack running down the length of the gear shaft which will eventually cause the WBA to emit a gear grinding noise and begin exhibiting slow or erratic operation. This condition can be detected by pressing on the flag side of the gear and watching for downward movement. The gear should not slide down on the compression fitted shaft. If it does, the encoder gear needs to be replaced.

JCM Latest Software Listing

UNIT	ID	Version*	Check Sum
WBA-10/11-SS	ID-003	V-3.34-25	DBA9
WBA-10/11-SS	ID-022/023	V-3.34-03	7FCF
WBA-10/11-SS	ID-024	V-3.34-29	FF9F
WBA-12/13-SS	ID-003	V-3.34-21*	1185
WBA-12/13-SS	ID-0C3	V-3.34-09i*	F1C3
WBA-12/13-SS	ID-003 (Aristocrat)	V-3.34-22i*	11DB
WBA-12/13-SS	ID-003 (Spieio)	V-3.34-23i*	FA6F
WBA-12/13-SS	ID-003 (Bally)	V-3.34-25i*	2994
WBA-12/13-SS	ID-022/023	V-3.34-03i*	5A07
WBA-12/13-SS	ID-044C	V-3.34-05i*	144E
WBA-12/13-SS	ID-044	V-3.34-05i*	FD8D
WBA-12/13-SS	ID-023B	V-3.34-04i*	DF4E
WBA-12/13-SS	ID-024	V-3.34-27	8999
DBV-200-B0/B1	ID-022/023	V-2.51-04-03	32FC
DBV-200-A2/A3	ID-004/BAR	V-2.50-05	8F51
DBV-200-A2/A3	ID-044P/045P	V-2.50-05	8BD0
DBV-200-A2/A3	ID-011/015	V-2.50-09	5B42
DBV-200-A2/A3	ID-044/045W	V-2.50-04	5151
DBV-200-A2/A3	ID-044WP/045WP	V-2.50-05	D273
DBV-200-B4/B5	ID-024	V-2.50-09	070D
DBV-200-B4/B5	ID-003	V-2.50-02	44EE

* an "i" suffix indicates Intelligent Cash Box option.

UNIT	ID	Version	Check Sum
TSP-02	033	2.01	C11F
TSP-02	024CE (Caesar's Entertainment)	2.04	ECCF
TSP-02	024JC (New Jersey Caesar's Entertainment)	2.04	EE7F
TSP-02	024LT (Lottery)	2.00	4E33
TSP-02	024NJ (New Jersey)	2.00	798E
TSP-02	024NV (Nevada)	2.00	8566
TSP-02	024NVW (Nevada - WMS)	2.00	EB22
TSP-02	033CE (Caesar's Entertainment)	2.00	6B31
TSP-02	033IL (Illinois)	2.00	7D8F
TSP-02	033JC (New Jersey Caesar's Entertainment)	2.00	95C5
TSP-02	033NJ (New Jersey)	2.00	6558
TSP-02	033NV (Nevada)	2.00	6178
TSP-02	033NY (New York - Lottery)	2.00	8EB8

NOTE: The list of JCM bill validator software provided herein notifies customers of the latest versions developed. However, the listing does not identify versions approved by gaming jurisdictional authorities for actual use. Customers should consult JCM's Customer Service/Parts Sales departments concerning approved versions for jurisdictions of intended use.

The JCM Ticket In - Ticket Out Solution ... Reliability, Durability, Productivity

The TSP-02 (Thermal Security Printer) by JCM was specifically designed to meet the needs of your Ticket In - Ticket Out casino operation. Our printer is designed to outlast the competition. With printers in the field that have been running for over two years with no field issues, JCM takes pride in the technology used in our printer solution. By designing the bill validator and the companion printer to go with it, JCM can guarantee the maximum in acceptance rates and printed ticket quality. Contact your local JCM Sale Representative today for additional information.

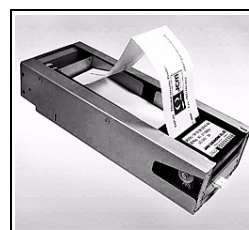



FREE REGIONAL TRAINING

Give your techs the tools they need to keep your customers happy and your equipment running at peak efficiency. Call for further information.

Dec. Las Vegas, Nevada
Jan. Las Vegas, Nevada

Technical Tips

Question: Does JCM issue Customer Notifications?

Answer: Yes. JCM has recently begun issuing Customer Notifications to cover software releases, product updates, and product changes. This is being done to ensure that our customers are fully informed about the latest vital product information they require to make JCM equipment run at its optimum performance level. We are developing a contact database of customer e-mail addresses in order to send our Customer Notifications out as soon they are released.

If you would like to add your contact information to our list, please e-mail techsupport@jcm-american.com and include your name, title, company, and e-mail address in the correspondence.

Our current and archival Customer Notifications can be viewed at the JCM Company website at www.jcm-american.com. Look under the **Customer Service/Technical Information/Customer Notifications** pulldown tab. This website area will allow you to access our most recent table of Customer Notification listings.

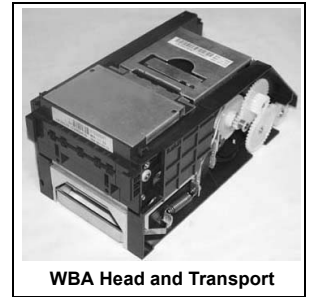

WBA Head and Transport

JCM is a registered trademark of JCM American Corporation. All other product names mentioned herein may be registered trademarks or trademarks of their respective companies. Furthermore, TM and ® are not mentioned in each case in this publication.

JCM American Corporation
925 Pilot Road
Las Vegas, Nevada 89119
Telephone: (702) 651-0000
Toll Free: (800) 683-7248
FAX: (702) 651-0003

